

VÁLVULA DE RETENÇÃO APROVADA ULFM

250 lb. WWP Iron Body Check Valves

Fire Protection Valve • UL listed FM Approved
 Double-Door • Wafer Style • Rubber Seat • Spring Actuated

200 PSI/13.8 Bar Non-Shock Cold Water General Service

UL/ULC LISTED • FM APPROVED*

MATERIAL LIST	
PART	SPECIFICATION
1. Body	Ductile Iron ASTM A 536, Grade 65-45-12 - 2" thru 12" 14" thru 16" Cast Iron ASTM 126, Class B
2. Disc	Bronze ASTM B 584 Alloy C83600
3. Torsion Spring	Stainless Steel
4. Hinge Pin	Stainless Steel
5. Stop Pin	Stainless Steel
6. Thrust Bearing	Stainless Steel
7. Hinge Pin Retainer	Steel
8. Stop Pin Retainer	Steel
9. Stabilization Sphere	Buna-N
10. Spacer	High Density Polyethylene



KW-900-W

Wafer Style
2 1/2" - 12"

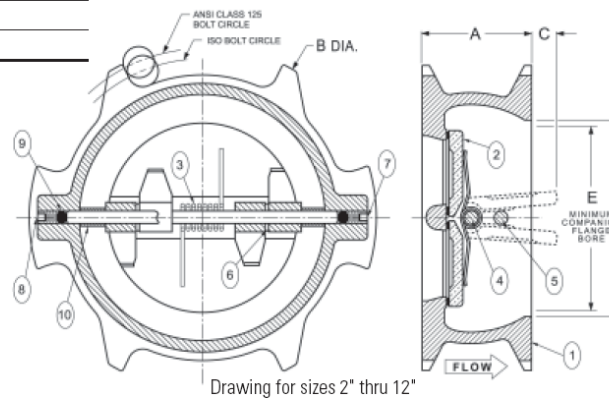

KW-900-W
Wafer

Drawing for sizes 2" thru 12"

DIMENSIONS—WEIGHTS—QUANTITIES

Size	Dimensions						C/V	Weight	
	A	B	C	D	E	Lbs.		Kg.	
In. mm.	In. mm.	In. mm.	In. mm.	In. mm.	In. mm.	In. mm.			
2 1/2 65	2.38 60	6.00 152	.125 3	3.50 89	1.313 33	108	4.3	1.95	
3 80	2.63 67	5.63 143	.188 5	3.875 98	1.688 43	178	6.1	2.77	
4 100	2.63 67	7.75 197	.625 16	4.75 121	3.063 78	440	8.8	3.99	
5 125	3.25 83	7.56 192	.813 21	5.50 140	3.625 92	560	13.0	5.90	
6 150	3.75 95	8.63 219	.813 21	6.25 159	4.250 108	840	18.0	8.16	
8 200	5.00 127	12.25 311	1.000 25	8.00 203	5.500 140	1600	37.0	16.78	
10 250	5.50 140	14.75 375	2.125 54	10.12 257	8.500 216	2700	65.0	29.48	
12 300	7.13 181	17.38 441	1.938 49	12.00 305	9.250 235	4700	94.0	42.64	
14 350	7.25 184	17.75 451	3.250 83	—	—	13.000 330	5200	200.0 90.75	
16 400	7.50 191	20.25 514	4.500 114	—	—	15.000 381	7200	285.0 129.28	

Note: 14" and 16" sizes, 200 PSI WWP, FM approved only – P.O.A.

Features

- Spring loaded for fast closure, eliminating reverse flow slam and water hammer.
- Easily installed, with gasket, between standard class 125 flanges.
- Only one set of flange studs is needed.
- May be installed in both horizontal and vertical lines with upward flow.

NOTE: 14" and 16" sizes, 150 PSI WWP, FM approved only – P.O.A.



sizes
4" - 12" only



KW-900-W

Wafer Style
14" - 16"

NOTE: Twin Disc Check Valves can be installed horizontally or in the vertical position with flow up.

CAUTION: For horizontal flow applications, the valve must be installed with disc hinge pin in the vertical position to insure proper operation.

WARNING:

1. These are not to be used as steam valves
2. Valves are not to be used near a reciprocating air compressor
3. Install 5 pipe diameters minimum downstream from pump discharge or elbows to avoid flow turbulence. Flow straighteners may be required in extreme cases.

NOTE: On pump discharge, the preferred check valves are in-line spring loaded, swing design with lever and weight or lever and spring.